

from **STANLEY**

TOOL BOX OF THE WORLD

come . . .

- | | |
|-------------------|--------------------------------|
| PLANES | TRY and MITRE SQUARES |
| LEVELS | STEEL SQUARES |
| "PUSH-PULL" RULES | CHISELS and PUNCHES |
| "ZIG-ZAG" RULES | CARPENTERS' CHISELS |
| BIT BRACKETS | GAGES |
| "CAST" BILLS | HAMMERS |
| WEDGES | DOWELING TOOLS |
| DRILL BIT SETS | SCREW DRIVERS |
| POUNDRERS | SPOKE SHAVES |
| LEVELS | |
| | STANLEY "SURFORM" TOOLS |
| | RUSSELL JENNINGS BITS |
| | "YANKEE" FINE MECHANICS' TOOLS |

For Complete List of Tools
Send for Catalog No. 34

STANLEY
TOOL WORKS
U. S. A.

1-118A 202-4-61

STANLEY

PISTOL GRIP SAW SETS

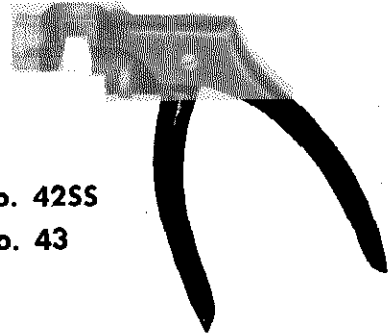

No. 42SS

No. 43

SMOOTH—EASY ACTION

STANLEY

"THE TOOL BOX OF THE WORLD"

ATTACHMENT FOR CIRCULAR SAWS

No. 43

The Saw Set No. 43 has the circular saw setting attachment for small circular saws packed loose in the box.

The attachment or stop is placed with the slotted end behind the washer and under the Set Nut shown in the illustration of the No. 43 Saw Set. It is adjusted so that the small end or finger of the stop is in contact with the top of the plunger. Follow general directions as for the setting of the teeth on cross cut or back saws.

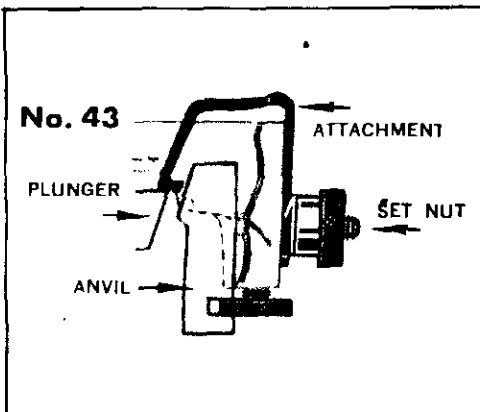

No. 42SS

The Saw Set No. 42SS has the attachment assembled to the frame (No. 5). It is turned around one of the way so it will not interfere with the setting of hand saws. For setting the teeth on circular saws 18 gauge and thinner, loosen the screw holding the attachment and turn it over. Replace it so that the small end or finger of the attachment is in contact with the top of the plunger. Follow general directions as given for hand saws.

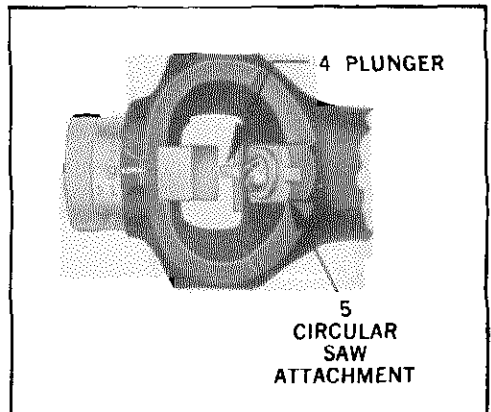

DIRECTIONS FOR SHARPENING

Before starting work read all the directions. Then, as you work, read them step by step. Examine the illustrations carefully. If possible examine a new saw to see just how the teeth should look when correctly sharpened.

The five operations essential for correctly sharpening cross cut or rip saws are:

1. INSPECTING

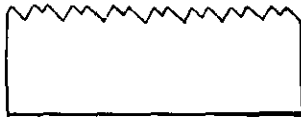

Fig. 1

Teeth of a saw that needs jointing

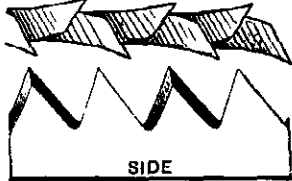

Fig. 2

Teeth of Cross Cut Saw showing correct shape

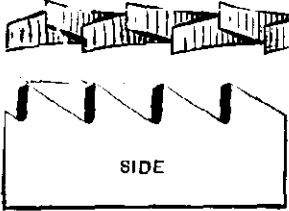

Fig. 3

Teeth of Rip Saw showing correct shape



Fig. 4
The Saw in
Fig. 1
after
jointing

Place the saw in a clamp with the handle to your right. Lay a mill file or saw jointer lengthwise on the top of the teeth. File lightly back and forth until the file touches the top of every tooth. Do not allow the file to tip to one side or the other. Figure 4 illustrates the saw teeth after jointing.

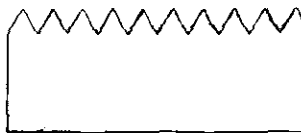

Fig. 5
Cross Cut
Saw
after
Shaping

After "jointing" all teeth must be filed to conform in outline to the shape as shown in Figure 5, for a cross cut saw or Figure 3 (side view) for a rip saw.

To obtain this shape place a taper file down in the gullet (space between two saw tooth points) and file across the saw at right angles to the blade — until you reach the center of the flat top made in "jointing." Then file in the next gullet until the flat top becomes a tooth point. All gullets should be the same depth after shaping. DO NOT TRY TO BEVEL THE TEETH AT THIS OPERATION.

2. JOINTING 3. SHAPING

4. SETTING 5. FILING

1. Inspecting

First examine carefully the tooth edge of the saw to determine how many of the succeeding operations are essential for that particular saw.

A. If the teeth are uneven as shown in Figure 1 it is necessary to proceed with operations 2, 3, 4 and 5.

B. If the teeth are of uniform size and correct shape as shown in Figure 2 and Figure 3, operations 2 and 3 will be omitted. Proceed with operation 4 "Setting" and 5 "Filing."

C. If the teeth are satisfactory except for dullness of the cutting edges, operation 5 "Filing" will be sufficient.

2. Jointing

3. Shaping

SHARPENING A SAW

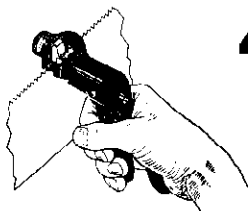

Fig. 6

Stanley No. 42SS Saw set in use

4. Setting



Fig. 7

Looking from back of the saw showing how teeth project when set

Setting a saw means bending over the upper $\frac{1}{3}$ to $\frac{1}{2}$ of the length of the tooth — every other tooth to one side of the blade and the in between tooth to the other side so that they will cut a path or kerf in the wood slightly wider than the thickness of the saw blade, to provide clearance. Normally this should give the blade of the saw a clearance of about 1/100 of an inch. CAUTION: If more than the upper half of the tooth is set or bent, you may crimp the blade or break a tooth. STANLEY No. 42SS Saw Set is used for setting teeth on ordinary hand, back and panel saws, both cross cut and rip. For large cross cut saws, use STANLEY No. 43 Saw Set.

5. Filing

Use a three cornered taper file. The size of file should be determined by the number of tooth points per inch on the saw blade.

The file size is shown in this table:

5 pt. and 5½ pt.	CROSS CUT — 6" reg. taper file
6, 7, 8 and 9 pt.	" " 4½" " " "
10 and 11 pts.	" " 5½" slim taper file
4½, 5, 5½ and 6 pt.	RIP 4½" reg. " "
4 pt. rip and coarser	" 6" " " "

A. Filing Cross Cut Saws

Place the saw in a clamp with handle to the right and teeth up. Flatten the top of teeth slightly as in jointing for a guide. Select the first tooth from the left that is set toward you. Place the taper file in the gullet to the left of this tooth. Hold file directly across the blade and then swing file to your left until it makes approximately a 65° angle with the saw blade. Be sure that the file fits down in the gullet and is not tipped to front or back. File on the push stroke until you cut away one-half of the flat top of the tooth that you made as a guide. You have now filed $\frac{1}{2}$ of the tooth that is to the left and $\frac{1}{2}$ of the tooth that is to the right at the same time. Skip one gullet and continue in the second gullet to the right with the same filing operation. Continue until you reach the handle. Then turn your saw around and clamp with the handle to the left. Place the file in the gullet to the right of the first tooth set toward you. (This gullet is the one skipped on the first filing operation.) File at an angle of 65° as in the previous operation until the flat top of the tooth is removed. Skip the next gullet and repeat this operation until you reach the handle.

Now place the saw on a board and run a flat file over the side lightly once on each side. This will remove any burrs and aids in making a uniform set.

B. Filing Rip Saws

Rip Saws are filed the same way except that instead of filing at 65° you file straight across or at right angles to the blade.

Figure 2 illustrates the bevel obtained in correctly sharpening a cross cut saw. Figure 3 shows a correctly sharpened rip saw.

NEW DESIGN SAW SET No. 42SS

FEATURES:

1. Micro-setting calibrated anvil adjustment wheel with positive locking screw — for securing desired setting.
2. Hardened and tempered tool steel anvil.
3. Adjustable graduated positive saw stop — provides compensation for variation in saw blade thickness to permit increasing the amount of set per tooth when desirable.
4. Easy, positive single action plunger — provides maximum setting power with minimum effort. Plunger of hardened and tempered tool steel.
5. Circular saw setting attachment provided in convenient location for quick application.
6. Pistol grip design originated by Stanley — for greater comfort and leverage. Body and lever made of malleable iron, practically unbreakable.

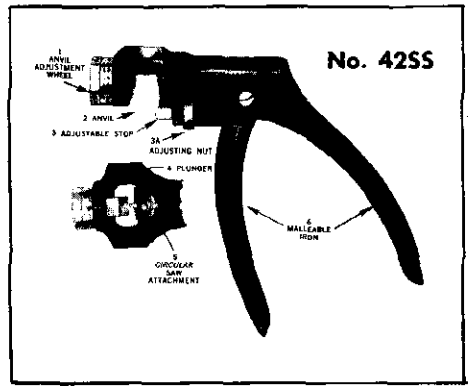

Capacity: Back, panel, hand and small circular saws, 18 gauge and thinner having from 4 to 16 points to the inch.

ADJUSTMENTS: The first adjustment to be considered when using this new saw set is the stop (No. 3) against which the saw blade is supported when the plunger (No. 4) is setting a tooth.

The side of this stop has 3 graduation lines and when it leaves the factory, it is set on the middle line which is for the average saw thickness. Normally you want to adjust this stop so that the blade of the saw is at right angles to the plunger when resting against the stop on one side and the point of the anvil (No. 2) on the other. For thicker or thinner saw blades, the stop is adjusted to maintain the blade at right angles to the line of travel of the plunger. The stop may also be adjusted to tilt the blade either forwards or backwards in order to obtain more or less angle of set on the tooth.

TO ADJUST THE STOP . . . rotate the adjusting nut (3A) to bring the stop in the desired position. A friction spring is provided to keep the adjusting nut from changing position.

The number on the anvil adjusting wheel (No. 1) indicates an average setting for saws with a corresponding number of points per inch. There is one less tooth per inch than there is points. (See illustration Figure 8). It should be recognized that it may be necessary to go to a lower number or mark as well as the adjustment of the stop if more set is necessary for green unseasoned wood or a higher number or mark if less set is desired for dry wood. Reference marks on the wheel have also been provided to help the professional saw sharpener who may want to determine his own settings. Once a setting is made, the slotted screw should be tightened to lock this setting against accidental movement.

TO ADJUST THE ANVIL SETTING . . . first loosen the slotted screw inside the adjusting wheel (No. 1) and rotate the wheel to bring the numeral that corresponds to the number of points as explained above, opposite the graduation line on the body, being sure to again tighten the locking screw when the desired setting has been made.

This single action saw set provides maximum power for tooth setting with minimum effort making it possible to obtain uniform even settings of the teeth of a saw.

This saw set is carefully designed for long and reliable service but the working parts are replaceable when necessary. When reordering parts for No. 42SS Saw Set be sure to specify the complete number shown inside the handle.

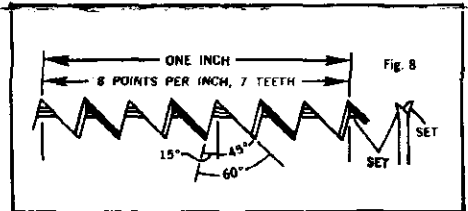

SAW SET No. 43

Capacity: Large Cross Cut Saws such as Buck Saws, Two Man Saws, and Circular Saws 11 gauge or thinner, having 5 or less teeth to the inch.

This Saw Set is provided with a Stop Plate for adjustment for the thickness of the saw blade. Adjust Stop Plate so that the blade of the saw is at right angles to the plunger when resting against the Stop on one side of the saw blade and the tooth of the saw against the point of the anvil on the other. It can be adjusted for thicker or thinner saw blades as necessary or for slightly more or less set of the saw teeth.

The tool is set for cross cut saws of average thickness. An attachment is furnished for setting small circular saws.

